

The relation between the change of terry towels machine type and its effect on the beat-up force

Prof. Mohammed Dorgham

Spinning, Weaving and Knitting Dept., Faculty of applied arts, Helwan University

ms.dorgham@yahoo.com

Prof. Abd-Elmonem Fouda

Spinning, Weaving and Knitting Department, Faculty of Engineering, Mansoura University

eabdo3@gmail.com

Researcher. Heba Elfowaty

Spinning, Weaving and Knitting Dept., Faculty of applied arts, Helwan university

gannamom@gmail.com

Abstract

This research aims to study the effect of changing the type of terry towel machine with different beating mechanisms, and weft density on the beat-up force by measuring it with a measuring system which was adopted and used that was reused after developing the technique of recording and analyzing signals. The principle of this measuring system depends on measuring the change in voltage in a measuring circuit as an indication to the change in beating-up force. The change in voltage is resulting from the change in the electrical resistance of the strain gauge which is affected by the beat-up force. This system which consists of sensing element, measuring circuit, digital oscilloscope and pc computer.

There are many factors that affect the quality of the terry towels produced, including the mechanical adjustments on the different weaving machines, as we find that the beating force responsible for the movement of the threads directly affects the stresses on the threads and thus affects the quality of the produced fabrics.

Since the terry fabrics have many and varied uses, we must reach the optimal way to produce high quality terry woven fabrics according to the research variables (beating-up mechanism - weft density).

Because the reed is responsible of picking the repeated wefts to the fabric, the beating force must be related to the quality of the textiles produced on the weaving machine, and the weaving design, which is affected by the used number of warp and weft threads.

Keywords:

Beat-up force, Terry towel machine, Electronic measuring system.

1-Review of literature

1-1. Introduction:

Terry towels are sometimes quite complicated, containing a variety of yarns of various types and colors, as well as diverse loop pile and flat structures. Towels are susceptible to changeable styles, and the market is continuously requiring new designs with better fabric properties, like as softness and absorbency, that are essential to users. The structure and composition of terry towels are essential considerations that determine the quality of the

finished product in meeting these parameters.

The goal of weaving machines improvement in strong areas is to increase productivity and quality. Customers are requesting more production capability and shorter item durations, which weaving machines are confronted. As a result, productivity refers to the capacity to create more meters of woven textiles in less time. In order to increase productivity, it is critical to decrease production time.

Changes in the warp beam and adjustments to the weaving machine, such as adjusting the working size or reed fineness, affect set - up time in weaving machine. Usually, machine staffs have the required knowledge to set up the machine settings are kept in the weaving mill's databases. [1].

Studies in the weaving machine are usually required in order to discover optimum setup settings for unknown products. Reduced downtime of weaving looms is also essential for increasing production. Incorrect weft insert or breaking warp yarns are the most common causes of downtime.

The warp tension is an important factor in the weaving process. A weaving machine's systemic study produced a simulated method for estimating warp yarn tension. The simulation's results were validated and found to be in a good agreement with reality.

A cost function was created that consider the required warp tension path. It is well known that weaving requires a minimum and regular warp tension course. The quality of the manufactured fabric might be increased by using the optimum setup settings on a machine. Later study of the produced textiles revealed that the modified weaving machine settings had no effect on the mechanical characteristics or production of the weaving process [2].

The Research problem:

Within the limits of the researches that have been addressed, there are not enough studies on effects of mechanical variables, parts of machines and the importance of the strong effect of changing beating mechanism of terry towel machine and variable weft density on the beat- up force, despite of the continuous technological progress and development in the technology of producing terry towels and the machines that are producing them.

The importance of the research:

The purpose of this study is to get the best operating specifications and operational requirements required to achieve the best specifications and mechanical settings for terry fabric manufacturing on advanced machines, and the optimal adjustment for each product operating specifications and choice of the best type of beating mechanism by creating measuring system to measure the beat-up force for the used terry towel machine.

Research objectives:

- Improving the terry fabrics produced by the machines by controlling the settings of the machines.
- Studying the change of machine settings, and putsuitable specifications for the technology of operating the machine.

- Achieving the optimal functionality of the terry fabrics by controlling the mechanical factors that have effect on the product, including the beating force of the reed for the terry towel machine.

Research hypotheses:

- Create electronic measuring system to measure the beat-up force of the reed for terry towel machine.
- Study the effect of changing type of beating mechanism on the value of beat-up force and its effect on towels.
- The influence of using variable weft density on the beat-up force and its impact on the produced terry towels fabric.
- The change in the mechanical settings of the textile machine has effects on the produced terry fabrics.

Research Methodology:

The analytical practical methodology.

1-2-Previous studies:

Although some previous researches made many attempts to study the beat up force due to different weaving variables, and studying the extent of its effect on the stresses on the warp threads, it was difficult to apply this in practice and link it to the analysis of the results of the produced samples.

*Some attempts have been made to measure the beating force; a wire strain gauge was inserted in grooves cut onto the face and back of reed wires to create the technique. An AC Wheatstone bridge was constructed using two strain gauges on a reed wire. The strain gauge wires were discovered to be extremely delicate, and the bending of a reed wire was impacted by the load given to the rest of the reed. Therefore couldn't quantify differences throughout the width of the fabric because of these variables. [3]

*The influence of shedding form (balanced or unbalanced shed) was studied, and also the sliding weft yarns during weaving, in a mathematical model of beat-up force. It also has actual expertise determining beating force with an instron tensile tester. Glass rods were used for the weft, while flexible threads were used for the warp. The real-world experience matched the mathematical models rather well. [4]

*The influence of weaving loom speed, total warp static tension, and yarn count on dynamical warp tension at beat-up and open shed positions were studied. The results showed that weaving loom speed and warp static tension had a considerable impact on dynamical warp tension in open shed, while machine speed, yarn count, and static tension had a substantial impact on the beat-up. [5]

1-3- Forces and stresses on weaving machine:

In the future, some factors, such as a yarn's dynamic behavior throughout the beat up process, were not included in the simulation. The effect of heddle motion, the friction generated by

yarn motion in the heddles were included to improve the simulation. [6]

During the weaving process, the textile material (warp) is stressed at a relatively high rate. As a result, a unique measuring instrument for analyzing beat up force in textile materials during the weaving process has been developed. [7]

In a weaving machine, fabric is created by a discontinuity process based on the cyclic repeating of single weaving cycle phases: opening a shed, interlacing the weft, beating up the weft, and close the shed. These weaves together are two yarn systems that are perpendicular to each other (warp and weft) [8].

The warp yarn is extended when open a shed and apply the beating force. The warp threads are subjected to dynamic stress of high frequency due to the higher weaving rates of advanced machines. [9]

1-4-The movement of reeds and measuring their performance rates

Figure (1.8) shows a projectile weaving machine's beating mechanism. Light-weight components are used for the beating movement in high-speed processes. The components should have a high degree of stiffness and a quick beating motion. The process of two beat-up positions of the reed is applied to various terry machines as shown in figure (1.9).

The filling yarn is pressed against the warp's frictional forces during beat-up. Beating up filling yarn needs a great amount of force.

The coefficient of friction between the warp and the filling affects the frictional force. Another reaction is caused by the crimp interchange bending of warp and filling yarns, to be able to overcome these reactions. The action of pressing the filling yarn into the fabric fell is known as beating-up since it is done in a somewhat rough manner. As the beating progresses towards the fabric fell, the beat-up force increases [10].

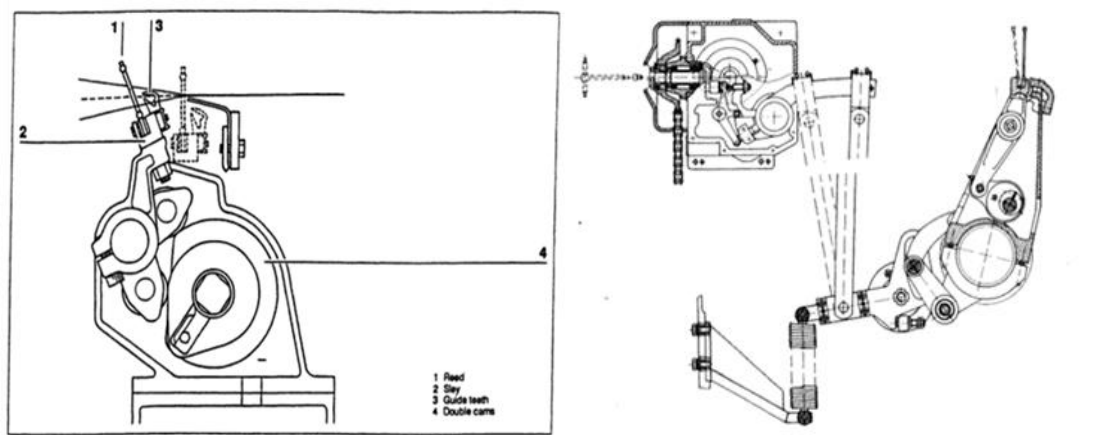

Fig (1) Beating mechanism of weaving m/c Fig(2)Double beat-up position of terry m/c

1-5- Different methods of obtaining pile fabrics by moving reeds:

The invention is a reed control device for a terry type loom. The reed control mechanism allows the reed to go through a three-pick cycle, with partial beat up on the first two weft picks and complete beat up on the third weft pick. A lay beam on which the reed is fixed by a crank arm whose motion is controlled by a rotational driving element receives reciprocating

motion. A mechanical linkage, which contains a pneumatic or hydraulic cylinder, connects the rotational drive element to the crank arm. The pneumatic or hydraulic cylinder is used to move the reed's arc, resulting in partial beat up of some weft picks and complete beat up of others.

Comparable reference characters identify similar components throughout the various viewpoints in the drawing figures that have not been created to scale [11]

-Through previous researches and studies, it is clear that the previous works have focused on the forces and stresses on weaving machine especially tension on warp yarns and the influence of the movement of the heddle although the beat up force and its effect on performance properties of fabric has not enough researches, so it is necessary to study more about the change in the beat-up process and its effect on the yarn stress, in this thesis we will create a measuring system for recording the beat-up force on two terry weaving machines with different beating mechanisms to produce terry towel samples with various variables.

2 –Experimental work:

The experimental program consists of two main parts:

- 1-The first part is the textile experiments where the research samples were produced.
- 2-The second part is the construction of an integrated electronic measurement system to measure the beating-up force of terry towel machine.

2-1. Produced research samples:

In the experimental part of this study, six woven terry samples of different weft density and beating-up mechanism of production machine were produced.

Usually, the structure of samples consists of three components, ground warp yarn, weft warp yarn and pile yarn which form the terry woven fabric.

2-1-1.The specifications of ground warp and weft yarns used for producing samples:

2-1-1-1. The specifications of ground warp yarns:

Table (1) shows the specifications of ground warp yarns are as follows:

The main parameter	Specification
Warp count	24/2 Ne
Reed number	12/cm
Denting	2 yarn/dent
Warp density	24Ends/cm
Yarn type	100% cotton carded ring spun

2-1-1-2.The specifications of weft yarns:

Table (2) shows the specifications of weft yarns are as follows:

The main parameter	Specification
Weft count	12/1Ne
Weft densities	10,15,20 Picks/cm
Yarn type	100% cotton carded ring spun

2-1-2. The fabric specifications of woven terry fabrics:

Table (3) shows the fabric specifications of terry fabrics:

Sample No.	Beating-up mechanism type	Weft count (Ne)	Weft density (picks/cm)	Pile type
1	M	12/1	10	both sides 3-pick pile
2	M	12/1	15	both sides 3-pick pile
3	M	12/1	20	both sides 3-pick pile
4	F	12/1	10	both sides 3-pick pile
5	F	12/1	15	both sides 3-pick pile
6	F	12/1	20	both sides 3-pick pile

*M= Movable beating mechanism.

*F= Fixed beating mechanism.

The above table shows the specifications of the produced six terry towel samples.

2-1-3. Manufacturing Method of the Terry Fabrics:

The terry fabrics were produced on two different terry towels machines Vamatex, SP1151es and Sulzer, Tps600 Terry Model.

This experiments were done at EL-FOWTY TEX Company for weaving in EL-Mahlla, Egypt to be able to use the machine variation.

To perform the three -pick terry towel fabric, the threads from both series (pile and ground) are drafted in pairs in the manufacturing of terry fabrics. They're also passed through the reed in pairs, so two warp threads from the same series end up in the same reed dent. When looking at the design (Fig.3), it will be noticed that successive ground warp threads, as well as consecutive pile warp threads, interweave in an opposite manner.

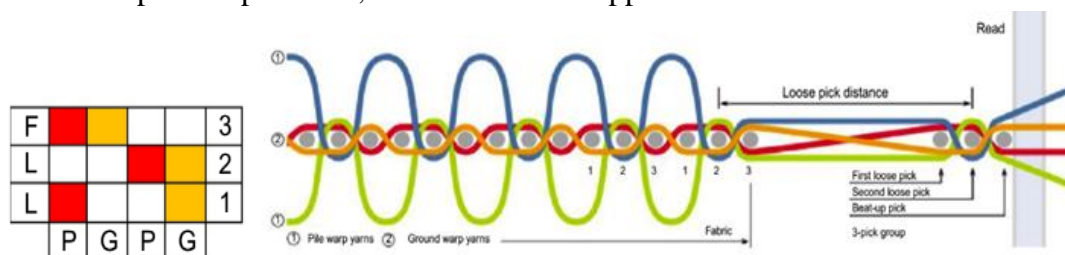

Fig (3) Graphic design of 3-pick terry towel.

2-1-4. The specifications of production machines:

Table (4) shows the weaving machines specifications:

Type of weaving machine	VAMATEX ,SP1151es	SULZER, Tps600
Weaving machine speed	280 rpm	280 rpm
Cloth width	240 cm	260 cm

Width of machine	260 cm	280 cm
Loom height	80 cm	90 cm
Max loom height	110 cm	120 cm
Loom depth	160 cm	170 cm
Shedding mechanism	Electronic jacquard (Staubley – CX 870)	Electronic jacquard (Staubley – CX 870)
Take-up mechanism	Electronic Take-up roller	Electronic Take-up roller
Let-off mechanism	Electronic Let-off roller	Electronic Let-off roller
Picking method	Double Flexible Rapier	Double Flexible Rapier
Year of manufacture	2000	2002

2-2.Measuring the beating-up force of terry towel machine:

A measuring system was designed and it was used to measure the beat-up force with the help of technologies for capturing and analyzing signals. This measurement method works by using a change in voltage in a measuring circuit to signal a change in beating-up force. The voltage change is caused by a change in the electrical resistance of the strain gauge, which is controlled by the beat-up force. A sensing element, a measuring circuit, a digital oscilloscope, and a personal computer make up this system.

2-2-1. Sensing element:

The sensing element fig (4), which is positioned in front of the reed, is made up of a stainless steel channel with a length of 15cm, a width of 3.5cm, and a thickness of 2 cm, and a metallic spiral zipper that is screwed to the channel piece.



Fig (4) The sensing element

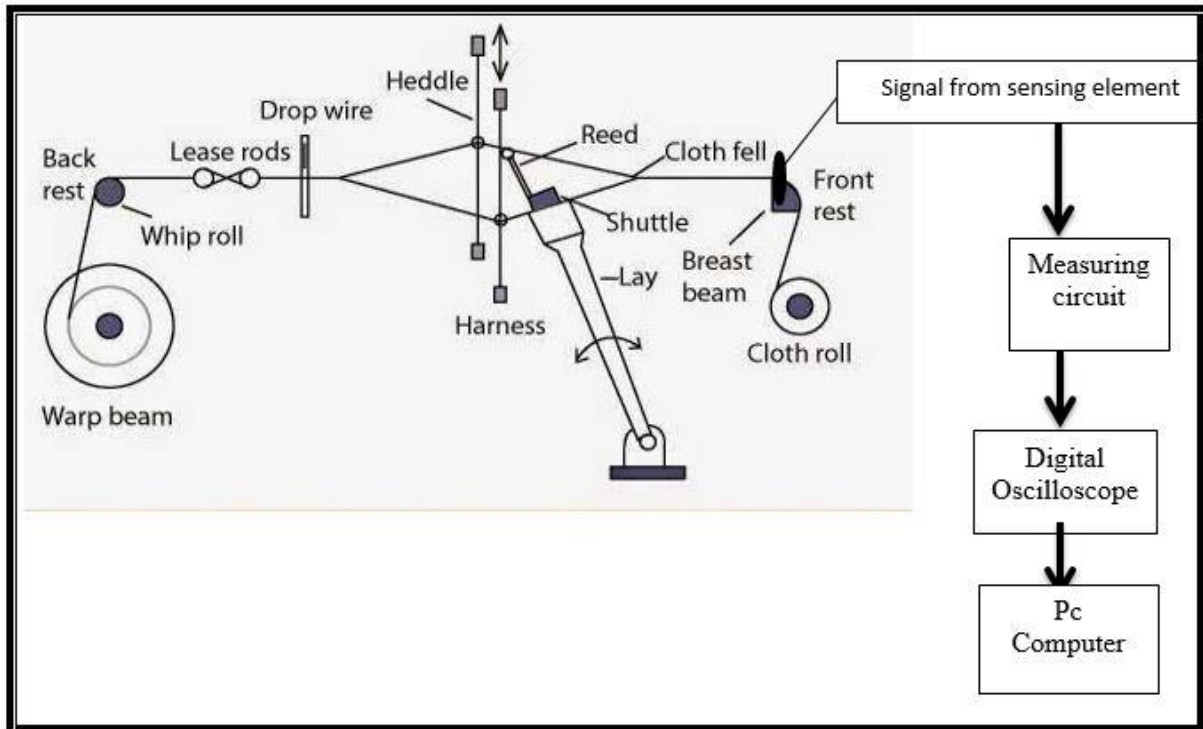

Fig (5): Positioning of sensor on the loom

2-2-2.Digital storage oscilloscope:

HX711 is a digital storage oscilloscope, as illustrated in fig. (6), employs a computer and its monitor to display waveforms or digital representations. In Windows operating systems, all typical oscilloscope features are provided. Its function is similar to that of a standard oscilloscope, with the exception that most operations may be completed online using a computer. It functions as a data acquisition system by transforming analogue to digital signals. It features four channels, allowing it to capture four signals at once.

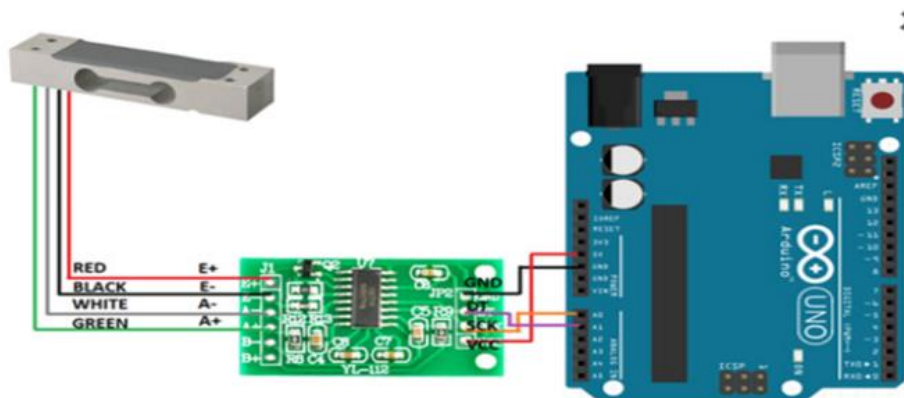

Fig (6) Weight Scale Analog to Digital Converter

2-2-3.Measuring circuit of PCB Board:

The measuring circuit of PCB Board is shown in Fig (7). The output of this circuit is recorded by the digital storage oscilloscope.

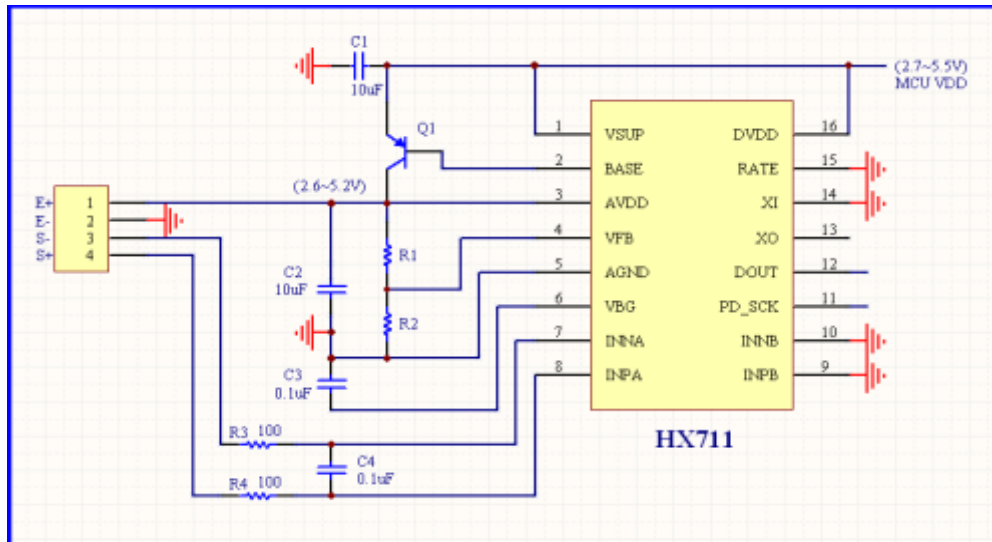

Fig (7) measuring circuit of PCB Board

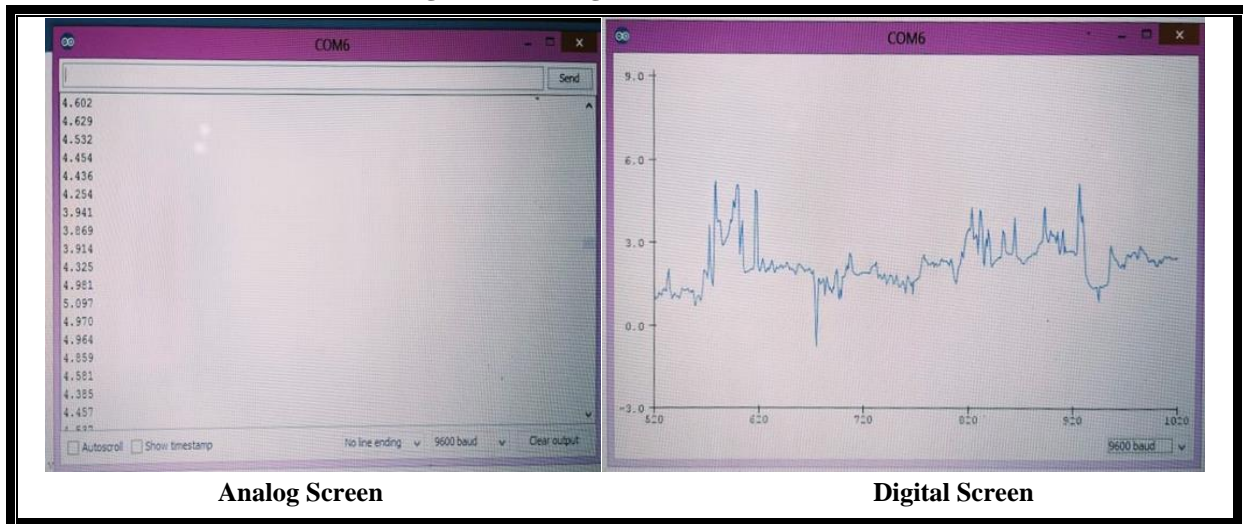

Fig (8) Windows screen of the digital storage oscilloscope program.

As illustrated in fig (8), the findings can be saved as an image or as a data file, which can subsequently be examined by computer programmes. Each record on the oscilloscope has 700 samples. For long-term recordings, the Automatic recording option (Auto save data) was utilised to store the data.

3. Results And Discussion

3-1. The research plan:

After applying the previous measuring system on VAMATEX and SULZER machines to produce terry towel fabrics at three different weft density with two different beating-up mechanisms of production machine.

The experiments plans were developed to create measuring system to measure the beat-up force of the reed for terry towel weaving machine.

3-2. The results of beating force:

Table (5) shows maximum beating force for samples

Sample no.	Max Force (N/beat)
1	158.56
2	172.88
3	180.45
4	304.5
5	324.8
6	366.9

3-3.The relationship between reading number of sensor and beating-up force:

3-3-1. Beating force of movable mechanism:

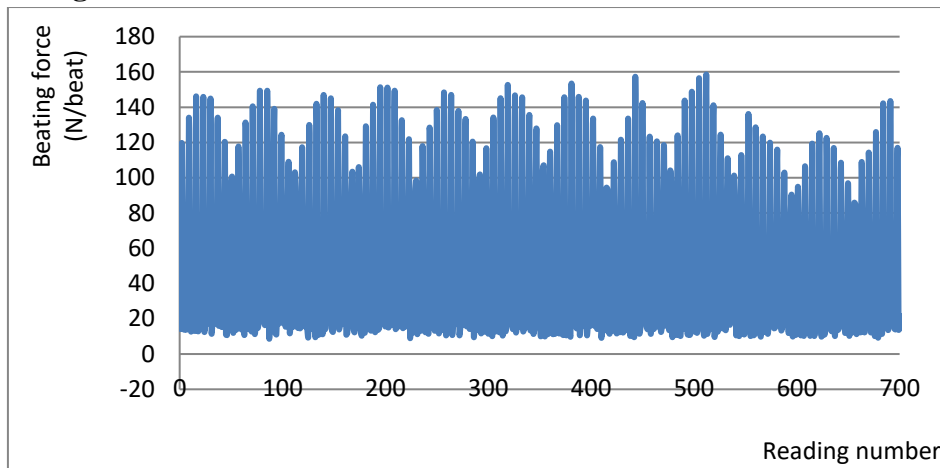

Fig (4) The beating force used at (280rpm),(10 picks/cm),(12/1 Ne).

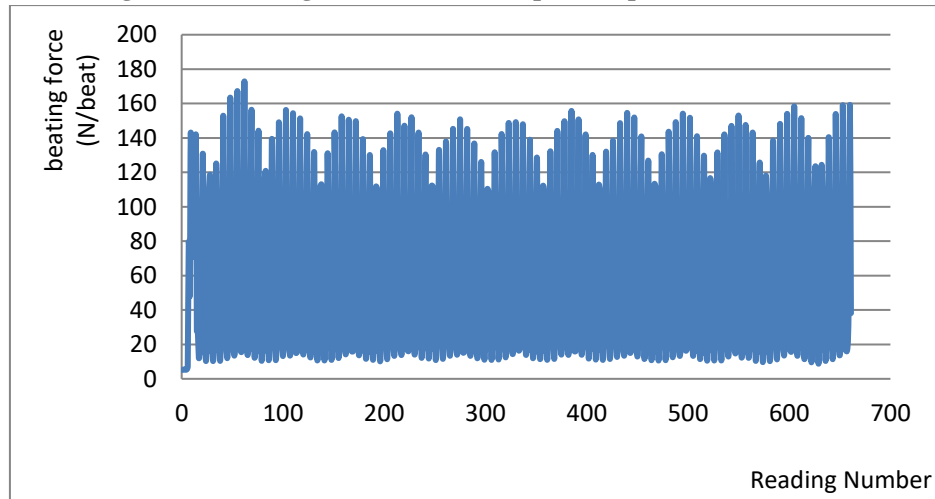

Fig (5) The beating force used at (280rpm),(15 picks/cm),(12/1 Ne).

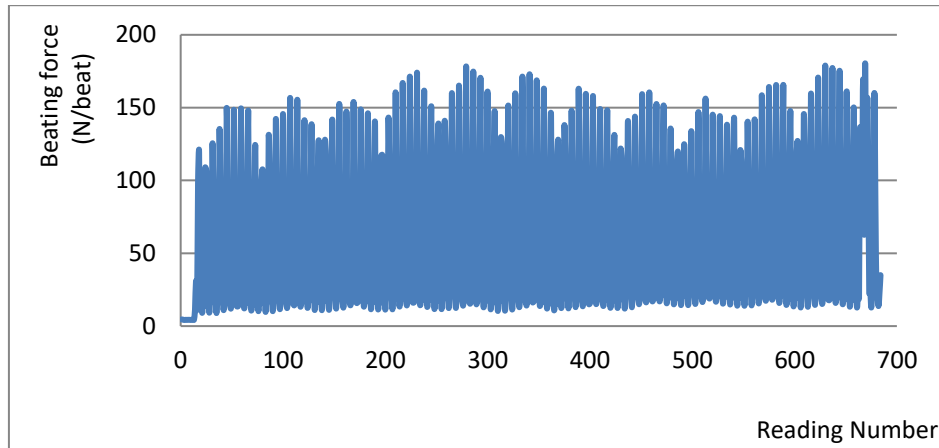

Fig (6) The beating force used at (280rpm),(20 picks/cm),(12/1 Ne

3.3.2-Beating force of fixed mechanism:

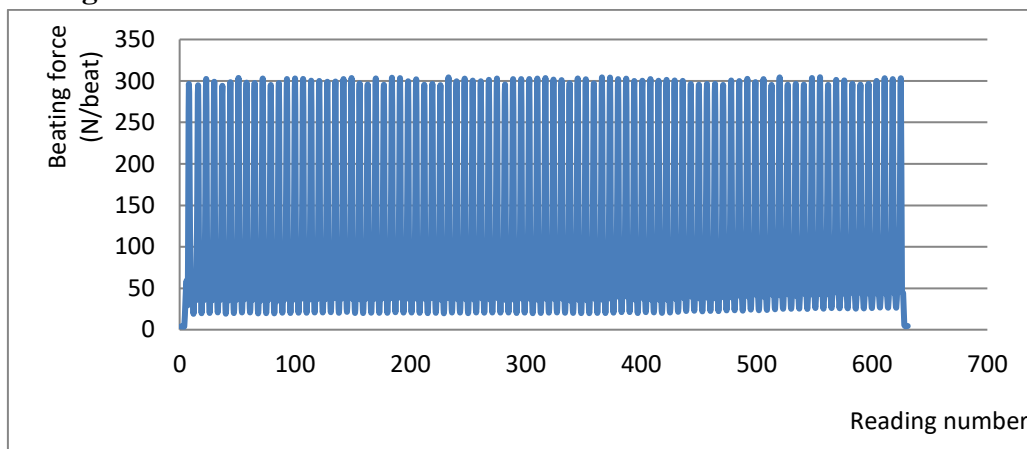

Fig (7) The beating force used at (280rpm), (10 picks/cm),(12/1 Ne).

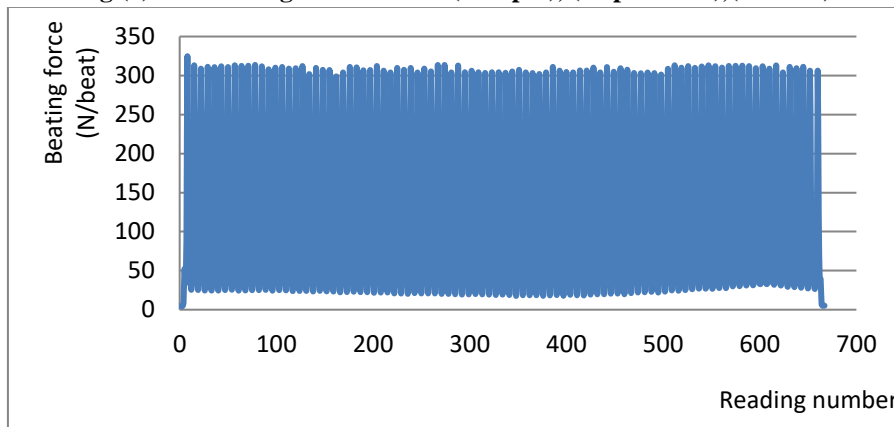
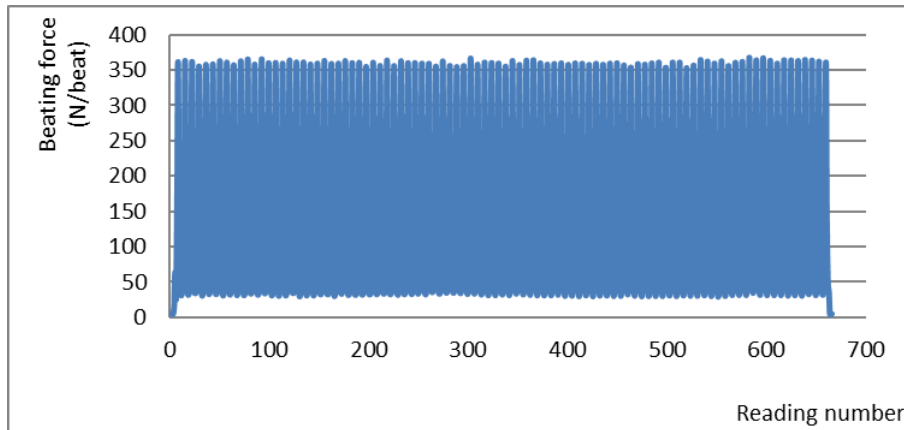

Fig (8) The beating force used at (280rpm), (15 picks/cm),(12/1 Ne).



Fig(9) The beating force used at (280rpm),(20 picks/cm),(12/1 Ne).

From the previous graph, it becomes clear to us that there is a clear difference to represent the force of the reed according to the type of beating mechanism, as we find that in the case of the movable mechanism, the higher values of the force, which represent the point of pile formation at the greatest force of the reed in the third beat, These values are changing up and down at a rate of constant variation according to the change in the let-off of warp device in the case of fixed mechanism, the highest values of the force are considered largely stable over the number of sensor readings through one minute time .

3-4. The relationship between the research variables and their effect on the beating force:

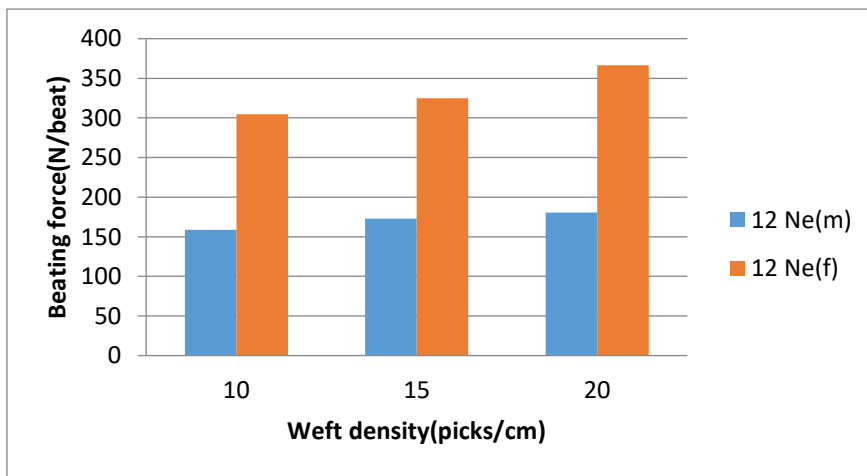

Fig (10) The beating force of (movable, fixed) Mechanisms at (10,15,20) picks/cm.

-The effect of weft density:

From the previous graph, it becomes clear to us that when the weft density used to produce terry towels samples increases, the beating force increases when the other variables are stable.

-The effect of changing the type of beating mechanism:

It is also clear that the use of the fixed mechanism requires a greater beating force than the use of the movable mechanism at the same operation speed of the machine and the stability of the other variables.

3.4.4-The beating force for all produced samples of terry fabric:

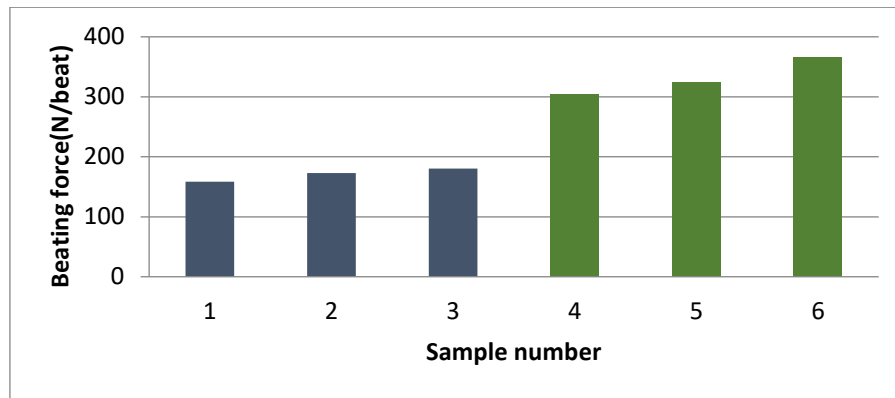

Fig (11) The beating force of six produced samples.

The previous graph shows us all the samples produced in this research and studying the change in the values of the beating force used to produce them. We note that the lowest value of the beating force is when producing sample No.1, which uses the lowest weft density (10picks/cm) , and using the movable beating mechanism, while the highest value of beating force is when producing sample No. 6, which uses the highest weft density (20 picks/cm) , and using the fixed beating mechanism.

3.5-Conclusions:

The following conclusions have been deduced based on the results of this study:

- 1- Establishing an integrated electronic measurement system fixed in front of the reed to measure the beat-up force of terry towels weaving machine.
- 2- The research variables as weft densities (picks/cm), and beating-up mechanisms affect to a great extent the value of beating-up force.
- 3- The customer may select the best features that will result in the most efficient use of terry towel and modern construction parameters to reach the required woven terry towel textiles.
- 4- With the help of quality evaluation, the less beating force, the less the stress, it was found that the best sample is No. (1) and the worse sample is No. (6).
- 5- We produce six different samples of woven terry textiles with varied constructional variables in this study, but the current approach may be used to any type of fabric.
- 6- We can also conclude that it is better to use the moving mechanism because it consumes less beating force and the stresses on the threads are less.

References

1. Schmitt, Robert, et al. "Self- optimizing production systems." *Integrative Production Technology for High-Wage Countries*. Springer, Berlin, Heidelberg, 2012. 697-986.
2. Gloy, Y. S., et al. "Simulation and optimization of warp tension in the weaving process." *Journal of Textile Science & Engineering* 5.1 (2015): 1.
3. Eldeeb, Ahmed Samy Mostafa. *The effect of loom settings on weaving resistance and fabric properties*. Diss. University of Leeds, 1982.
4. Ito, Tetsuo. *Some theoretical aspects of the effects of unbalanced shed and shed-timing on beat-up resistance in weaving*. Diss. University of Leeds (Department of Textile Industries), 1972.

5. Moray, A. E., and Eldeeb, Ahmed Samy Mostafa. "Study of Dynamical Warp Tension Behavior at High Speed Air-Jet Weaving Machine (Model Taudekoma). (Dept. T)." *MEJ. Mansoura Engineering Journal* 15.2 (2021): 65-79.
6. Mirjalili, Seyed Abbas. "Computer simulation of warp tension on a weaving machine." *Journal of Textile Engineering* 49.1 (2003): 7-13.
7. Bílek, M., Moučková, E., Skřivánek, J., & Tumajer. "Measuring of beat up force on weaving machines". In *MATEC Web of Conferences* (Vol. 89, p. 01003). EDP Sciences (2017).
8. Dvorak, J.; Bílek, M; Tumajer, P.: Vývojové trendy tkacíchstroju, available from <http://tkani.tul.cz/> , ACCESSED, 2015.
9. Tumajer P., Ursíny P., Bílek M., Mouková E.; *Research Methods for the Dynamic Properties of Textiles. FIBRES & TEXTILES in Eastern Europe 2011, Vol. 19, No. 5 (88) pp. 33-39.*
10. Adanur, Sabit. *Handbook of weaving*. CRC press, 2020., p.120-122,
11. Badawi, M. Sc Said Sobhey. "Development of the weaving machine and 3D woven spacer fabric structures for lightweight composites materials." (2008).,p.24-25.